

SWS MEDICAL
Science · Wellness · Safety ·

SWS-6000

Online HDF Hemodialysis Machine

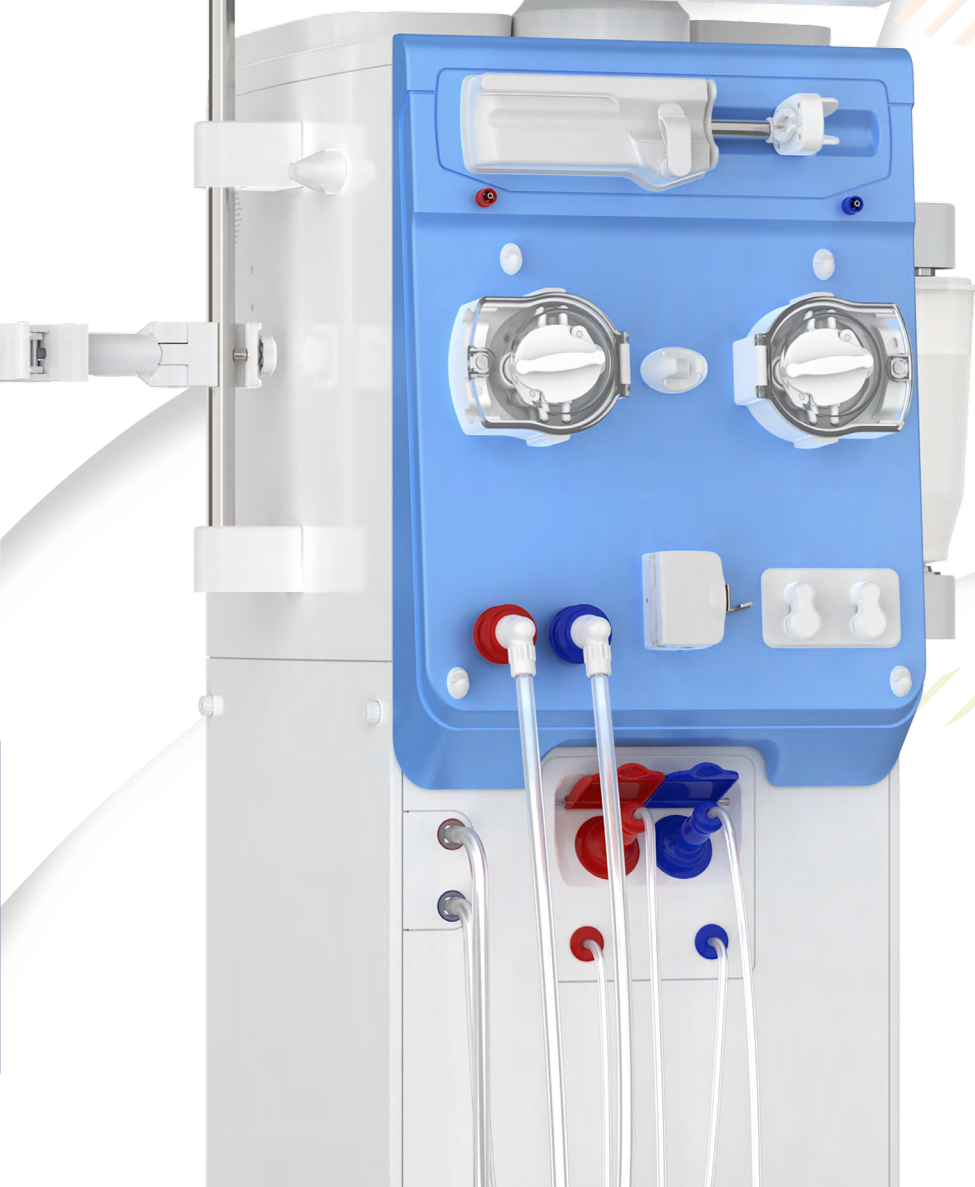

New Generation HDF Machine

Keep Dialysis Safe

Treatment Safety is Guaranteed

- The integrated design of the air detector, the venous clamp and blood recognition adopting the ultrasonic and optical sensor, which monitor the tiny bubble and identify the blood.
- * Online noninvasive BPM: Monitor heart rate and blood pressure changes of patients, communicate with the machine in real time, and ensure the safety of the treatment process.
- Advanced balance volume feedback control system ensures the accuracy of the UF.
- The dialysate mixing feedback control system ensures the accuracy of the dialysate ion.

Safe Self-test

- Independent control of hydraulic, blood circuit and monitoring systems to guarantee treatment safety.
- More than ten mandatory self-test items:
Balance system, fluid mixing system, UF system, Blood circuit system...
- Balance system real-time leak detection to ensure accuracy ultra-filtration.

Saving Cost

- Central Supply Concentrate interface: It is suitable for centralized control in large dialysis centers, eliminating manual handling, eliminating secondary pollution of concentrates, efficient management and controllable quality.
- Online prime and reinfusion: Using online substitution fluid to prime and reinfuse, without bag-type saline, fully automatic operation.

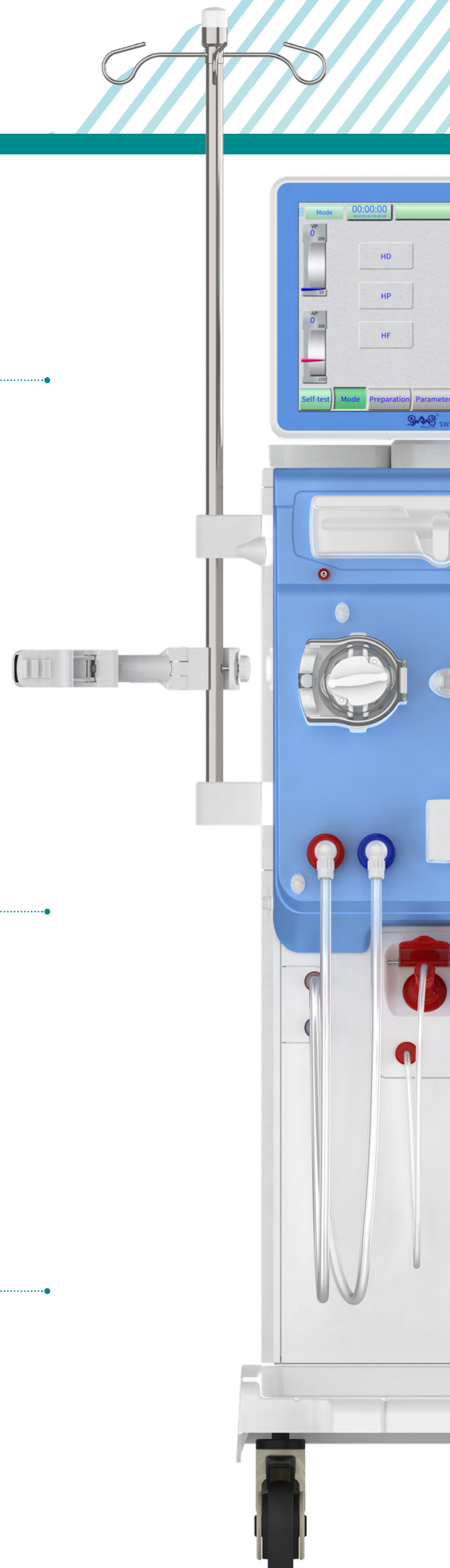

MARK: The * means optional part

Intelligent Design



User-friendly Operation Design

- The user-friendly guided design, self-test, parameter setting, treatment, cleaning and disinfection on a variety of operations interface.
- Multi-level authority management: Different setting permissions for doctors, nurses and engineers to ensure that the machine is operated correctly and to ensure the safety of treatment.
- Rotating screen can be rotated around, with large field of vision, and easy to take tray items.

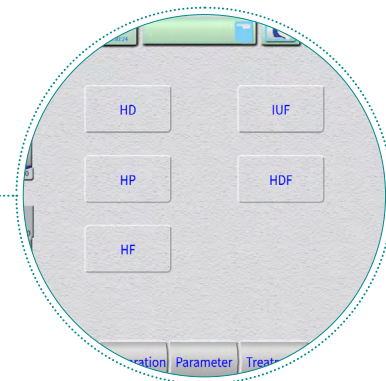

Easy Maintenance Design

- The front panel self-locking design, which is easy to open and save maintenance time.
- The other panel adopt knobs and screws, which can be disassembled easily without instruments.
- The electronic module with card-style design, which is easy to disassemble and maintenance.
- Magnetic suction door design makes it easy to replace the double endotoxin filters.

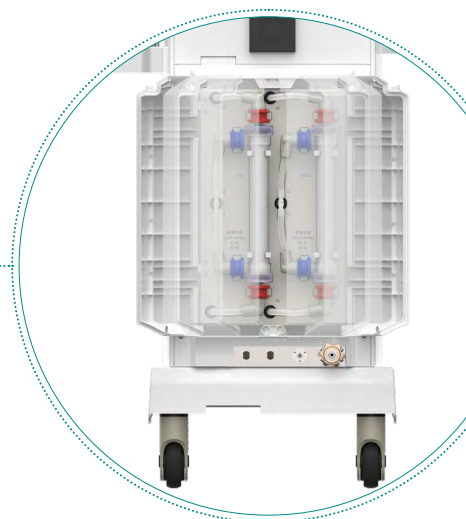

Multi-function Upgrade

- Compatible with all brands of dialysis consumables, a variety of dialysate formula + customize formula, which adapt to various concentrate and disinfectant.
- Multi-functional Heparin Pump: Automatic identification of syringe model (for 10ml, 20ml, 30ml, 50ml syringe), heparin profile available.

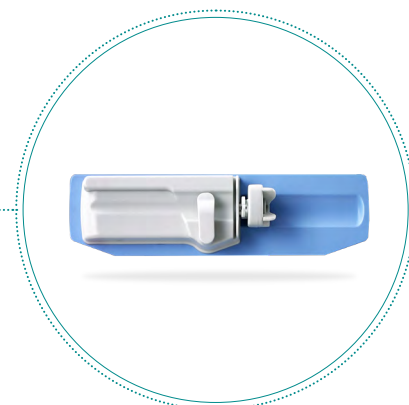

Clinical Treatment Program

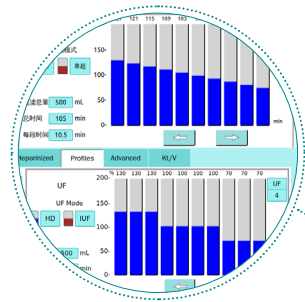

Multi-Treatment Profiles, Provide Customize Treatment

- Various Sodium Profile
- UF Rate Profile
- Bicarbonate Profile
- Heparin Flow Profile
- Dialysate Flow Profile
- Dialysate Temperature Profile

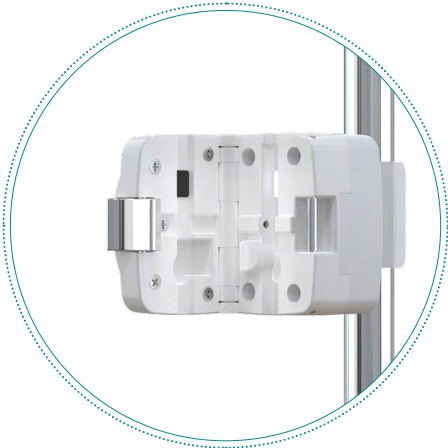

* BVM

- Blood volume changes can be accurately detected during treatment, effectively preventing hypotension caused by excessive water removal.

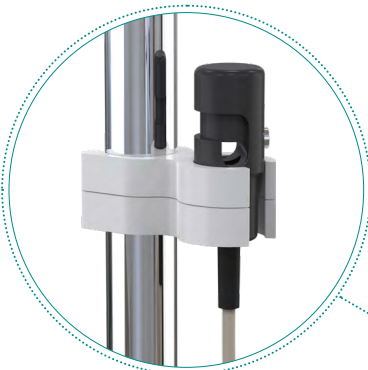

* OCM

- Real-time monitoring clearance efficiency of urea to ensure treatment sufficiency.



* BTM

- Monitor blood temperature of arterial outflow and venous inflow, maintain the balance of thermal energy of extracorporeal circulation, stabilize patient's body temperature, and effectively reduce the complications during dialysis treatment.

* Bicart Holder

- Isolation of B concentration microbial contamination to ensure the purity of the dialysate and improve the quality of treatment.

Online HDF

Improve The Quality of Life For Dialysis Patients

SWS-6000

Online HDF is a treatment much closer to kidney metabolism, studies shown that all-cause mortality is reduced by one third compared with HD, improving patient life quality and survival rate.

Online HDF treatment produce high quality sterile substitution fluid online...

- Removal of large, medium and small toxin molecules extensively.
- Stable hemodynamics.
- Improve microinflammation.
- Improve the nutritional status of patients.
- Improve patient survival rate and reduce cardiovascular damage.
- Improve erythropoietin reaction.

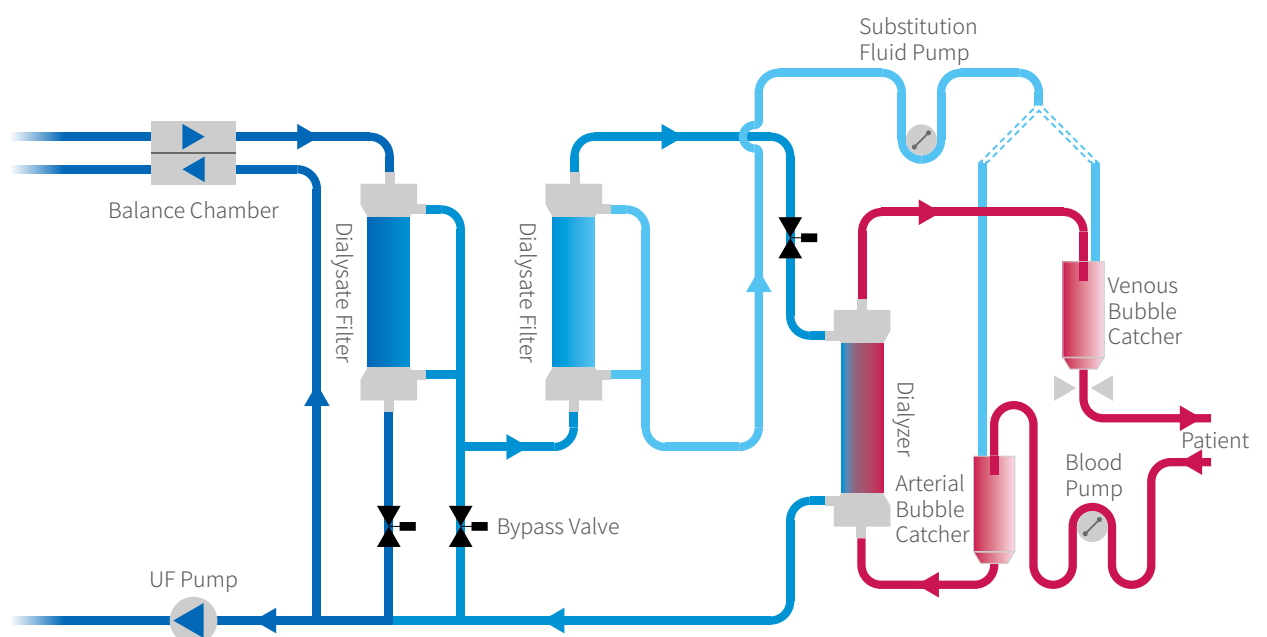

Professional Technical Services

- Professional Technical Services: Professional technical services team, which can provide real-time response to hospital requirement and can offer solutions in 12 hours, so that ensure the carefree usage.
- Free Regular Training: offer regular training to the medical staffs, which can strengthen sensitivity of medical staffs and emergency response for equipment operation.



SWS MEDICAL
Science · Wellness · Safety ·

Website: www.swskj.com

Tel: 86 23 6342 8507

Email: info@swskj.com

Address: No.1 Ciji Road, Liangjiang New District, Chongqing, China